

# Technical Service Bulletin

**NUMBER:** 08-006-00 REV. A

**GROUP:** Electrical

**DATE:** Dec. 29, 2000

*This bulletin is supplied as technical information only and is not an authorization for repair. No part of this publication may be reproduced, stored in a retrieval system, or transmitted, in any form or by any means, electronic, mechanical, photocopying, or otherwise, without written permission of DaimlerChrysler Corporation.*

**THIS BULLETIN SUPERSEDES TECHNICAL SERVICE BULLETIN 08-06-00, DATED FEBRUARY 25, 2000, WHICH SHOULD BE REMOVED FROM YOUR FILES. ALL REVISION ARE HIGHLIGHTED WITH \*\*ASTERISKS\*\* AND INCLUDE PART APPLICATIONS AND ADDITIONAL MODELS.**

***SUBJECT:***

Wire Splice Repairs

***DISCUSSION:***

This bulletin provides a revised wire splice procedure and related parts. This is the only procedure approved by DaimlerChrysler Engineering. This procedure must be used anytime a wire splice repair is required.

***MODELS:***

1989 - 1995	(AA)	Spirit/Acclaim/Lebaron Sedan
1989 - **2001**	(AB)	Ram Van/Wagon
1989 - 1993	(AC)	Dynasty/New Yorker/New Yorker Salon
1989 - 1993	(AD)	Ram Truck
1989 - 1994	(AG)	Daytona
1989	(AH)	Lancer/Lebaron GTS
1989 - 1995	(AJ)	Lebaron Coupe/Lebaron Convertible
1989 - 1990	(AK)	Aries/Reliant
1989 - 1990	(AL)	Horizon/Omni
1989	(AM)	Diplomat/Gran Fury/New Yorker fifth Avenue
1989 - **2001**	(AN)	Dakota
1989 - 1994	(AP)	Shawdow/Sundance
1989 - 1995	(AS)	Town & Country/Caravan/Voyager
1990 - 1993	(AY)	Imperial/New Yorker Fifth Avenue
1988 - 1992	(BB)	Monaco/Premier
1990 - 1994	(BD)	Laser/Talon
1994 - **2001**	(BR/BE)	Ram Truck
1989 - 1992	(B2)	Colt Summit
1992 - 1995	(B3)	Colt Vista
1989 - 1995	(B7)	Stealth (2000 GTX Dodge/Eagle, Canada)
1992 - 1995	(B8)	Colt Vista Wagon/Summit Wagon

1993 - 1994	(B9)	Colt Summit
1998 - **2001**	(DN)	Durango
1992 - 1995	(ES)	Chrysler Voyager (International Market)
1995 - 2000	(FJ)	Sebring/Avenger/Talon
1996 - 2000	(GS)	Chrysler Voyager (International Market)
1995 - 2000	(JA)	Cirrus/Stratus/Breeze
**2001	(JR)	Sebring Sedan & Convertible/Stratus Sedan**
1996 - 2000	(JX)	Sebring Convertible
1993 - **2001**	(LH)	Concorde/Intrepid/Vision/LHS/New Yorker /300M
1989 - 1992	(MJ)	Commanche
1996 - 2000	(NS)	Town & Country/Caravan/Voyager
1995 - **2001**	(PL)	Neon
**2001	(PT)	PT Cruiser**
1997 - **2001**	(PR)	Prowler
**2001	(RG)	Chrysler Voyager (International Markets)**
**2001	(RS)	Town & Country/Caravan/Voyager**
**2001	(ST)	Sebring & Stratus Coupe**
1996 - **2001**	(SR)	Viper/Viper GTS
1997 - **2001**	(TJ)	Wrangler
1999 - **2001**	(WJ)	Grand Cherokee
1989 - **2001**	(XJ)	Cherokee/Wagoneer
1989 - 1995	(YJ)	Wrangler
1996 - 1998	(ZG)	Grand Cherokee (International Markets)
1993 - 1998	(ZJ)	Grand Cherokee/Grand Wagoneer

**PARTS REQUIRED:**

Qty.	Part No.	Description
AR	05018395AA	Kit, Splice Band, Contains: One splice Band, p/n 05018396AA, And Heat Shrink Tube
AR	05018526AA	Kit, Splice Band, Contains: One Splice Band, p/n 05013243AA, And heat Shrink Tube
AR	05018527AA	Kit, Splice Band, Contains One Splice Band, p/n 05013251AA, And Heat Shrink Tube
AR	05018528AA	Kit, Splice Band, Contains: One Splice Band, p/n 05018397AA, And Heat Shrink Tube
AR	05018620AA	Kit, Splice Band, Contains: 200 Splice Bands, 50 Of Each Size, 200 Heat Shrink Tubes, p/n 04778570, and instruction sheet

**NOTE: IF THE REPAIR REQUIRES ADDITIONAL WIRE ALWAYS USE THE SAME OR NEXT LARGER GAUGE WIRE.**

**EQUIPMENT REQUIRED:**

05019912AA	MOPAR Crimping Tool Or Equivalent
------------	-----------------------------------

**REPAIR PROCEDURE:**

1. Remove one-half (1/2) inch of insulation from each wire that needs to be spliced.
2. Place a piece of sealant lined heat shrink tubing, p/n 04778570, on one side of the wire. Make sure the tubing will be long enough to cover and seal the entire repair area.
3. Place the strands of wire overlapping each other inside of the splice band (Fig. 1).

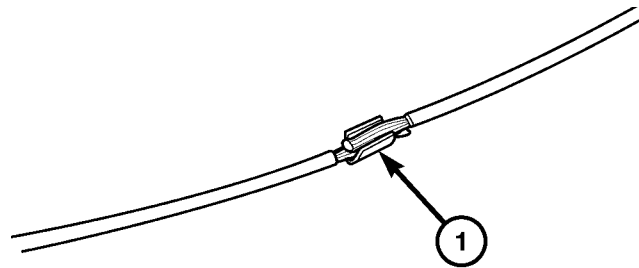

80c4f3f1

**Fig. 1 SPLICE BAND**

1 - SPLICE BAND

---

4. Using crimping tool, Mopar p/n 05019912AA, crimp the splice band and wires together (Fig. 2).

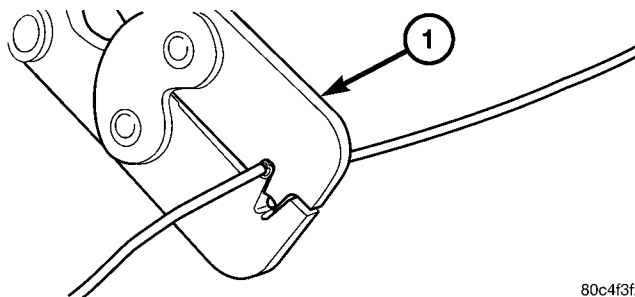

80c4f3f2

**Fig. 2 CRIMPING TOOL**

1 - CRIMPING TOOL

---

**CAUTION: DO NOT USE ACID CORE SOLDER.**

5. Solder the connection together using rosin core type solder only (Fig. 3).

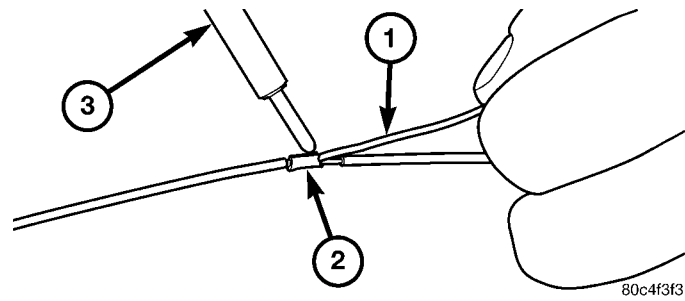

**Fig. 3 SOLDER SPLICE**

- 1 - SOLDER
  - 2 - SPLICE BAND
  - 3 - SOLDERING IRON
- 

6. Center the heat shrink tubing over the joint and heat using a heat gun. Heat the joint until the tubing is tightly sealed and sealant comes out of both ends of the tubing (Fig. 4).

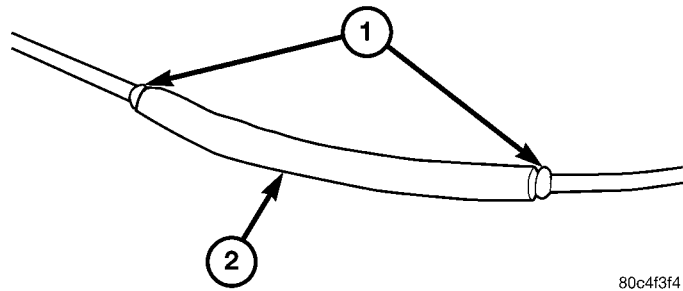

**Fig. 4 HEAT SHRINK TUBE**

- 1 - SEALANT
  - 2 - HEAT SHRINK TUBE
- 

**POLICY:**  
Information Only

**WIRING REPAIR SPLICE REQUIREMENTS**

<b>TWO WIRE SPLICES</b>							
		...to one wire this size (fused circuit)					
		22	20	18	16	14	12
One wire this size ...	22	05018395AA					
	20	05018395AA	05018395AA				
	18	05018395AA	05018395AA	05018395AA			
	16		05018395AA	05018526AA	05018526AA		
	14			05018526AA	05018527AA	05018527AA	
	12				05018527AA	05018528AA	05018528AA

<b>THREE WIRE SPLICES</b>							
		...to two wires this size (fused circuit)					
		22	20	18	16	14	12
One wire this size ...	22	05018395AA					
	20	05018395AA	05018395AA				
	18	05018395AA	05018395AA	05018526AA			
	16		05018526AA	05018526AA	05018527AA		
	14			05018527AA	05018527AA	05018528AA	
	12				05018528AA		